

KINCROME

PROFESSIONAL QUALITY TOOLS

DUAL WAY TORQUE WRENCH CLICK-TYPE

DUAL
SCALE

ACCURACY
+/-4%

PROTECTIVE
BLOW
MOULD
CASE

WORKS
IN BOTH
DIRECTIONS



K8036	1/4" 2-10Nm
K8500	3/8" 10-50Nm
K8501	1/2" 40-200Nm
K8502	1/2" 60-340Nm
K8503	3/4" 150-750Nm
K8504	1" 200-1000Nm

Table Of Contents

Know Your Product	2
General Safety Instructions	3
How To Use Your Torque Wrench	3-4
Tips & Tricks For Your Torque Wrench	5
Torque Measurement Conversions & Specifications	6
Spare Parts	7
Care & Maintenance.....	7
Warranty.....	7

Know Your Product

1. Square Drive
2. Quick Release Button (not included for K8502/3/4)
3. Forward/Reverse Switch
- 4a. Nm Scale
- 4b. lbf-in Scale(not shown)
5. Fine Scale
6. Locking Ring
7. Knurled Grip



GENERAL SAFETY WARNINGS

1. Please study these instructions carefully before attempting to operate this wrench.
2. Never apply more torque than the maximum scale reading.
3. This torque wrench is designed for manual tightening of threaded fasteners only.
4. **DO NOT USE IT AS A NUT-BREAKER OR FOR ANY OTHER PURPOSE.**
5. Over torqued or defective fasteners and sockets may suddenly break. **TO PREVENT INJURY, KEEP PROPER FOOTING AND BALANCE AT ALL TIMES. DO NOT USE THE WRENCH IN PLACES FROM WHICH YOU MAY FALL OR SLIP, OR AROUND ROTATING MACHINERY.**
6. This torque wrench will not prevent you from applying more torque than set - this is not a torque limiting tool. Learn how different amounts of torque 'feel' so you will reduce the possibility of damage and/or injury due to accidental over torquing.
7. **APPLY FORCE TO THE GRIP ONLY. DO NOT USE 'CHEATER BARS'**
e.g. (A piece of pipe placed over the hand grip).
8. All torque wrenches should be calibrated at least once every 12 months or every 5,000 cycles, whichever comes first. (See care and maintenance section on pg.7 for full care procedure).
9. This torque wrench operates in both directions, to tighten left and right threads.
10. Lifetime Warranty does not cover calibration.
11. Be sure all components, including all adaptors, extensions drivers and sockets are rated to match or exceed the torque being applied. (See pg.6 for calculating the effect of torque wrench extensions).
12. Always pull, do not push on the wrench handle and adjust your stance to prevent a possible fall should something give.

HOW TO USE YOUR TORQUE WRENCH



WARNING!

1. Your Torque Wrench is a precision instrument and should be treated as such.
2. Always store your Torque Wrench in the protective blow mould case.
3. If your Kincrome Torque Wrench is dropped, knocked, even in the protective blow mould case, or any part replaced, the wrench must be immediately re-calibrated prior to next use.
4. Ensure torque wrench is stored at its lowest setting. Calibration costs are the responsibility of the owner/user of the wrench.

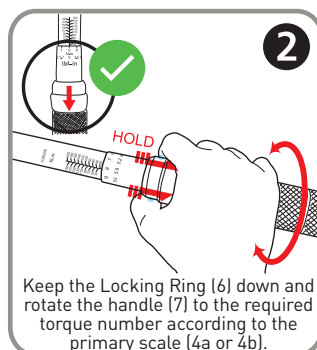
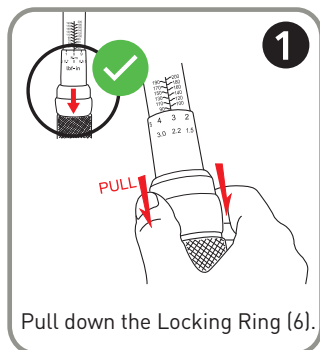

HOW TO USE YOUR TORQUE WRENCH (Continued)

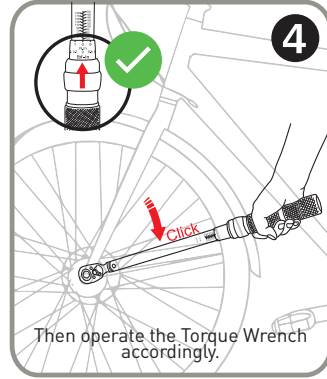
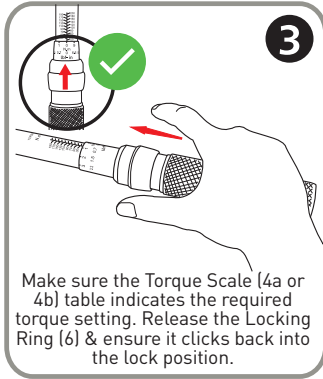

EXAMPLES OF TORQUE SETTINGS

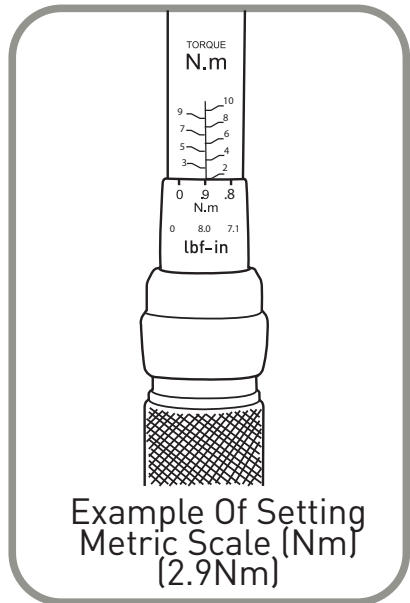
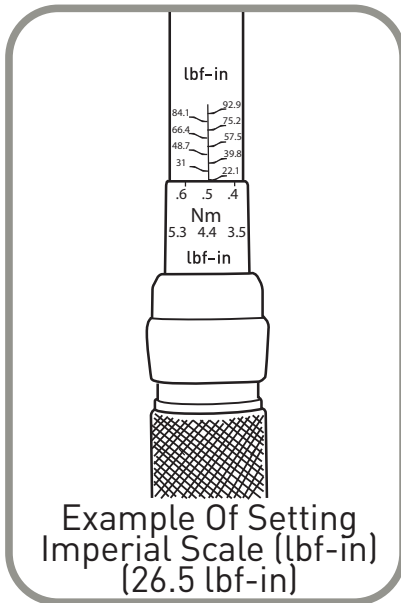

TIPS & TRICKS FOR YOUR TORQUE WRENCH

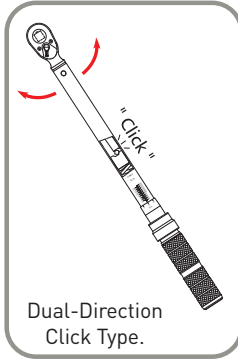

Dual-Direction Click Type.

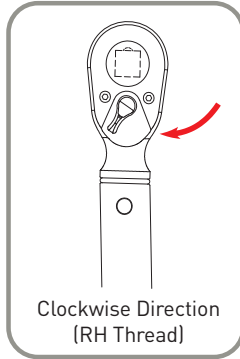

Clockwise Direction (RH Thread)

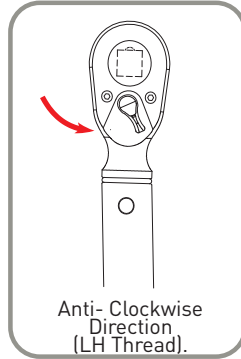

Anti-Clockwise Direction (LH Thread).

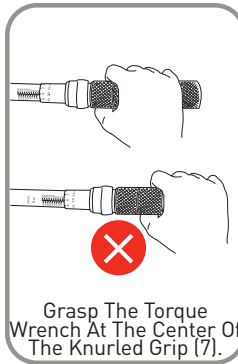

Grasp The Torque Wrench At The Center Of The Knurled Grip (7).

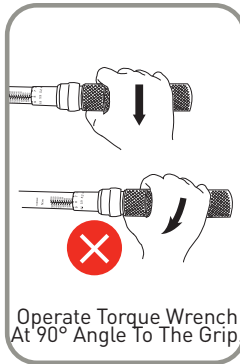

Operate Torque Wrench At 90° Angle To The Grip.

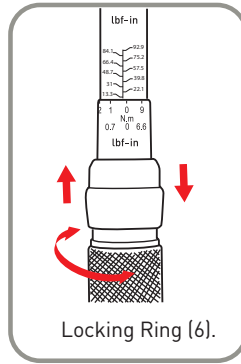

Locking Ring (6).

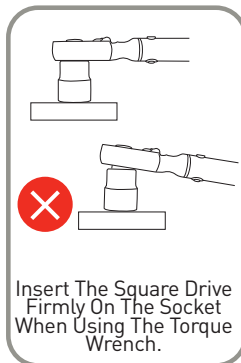

Insert The Square Drive Firmly On The Socket When Using The Torque Wrench.

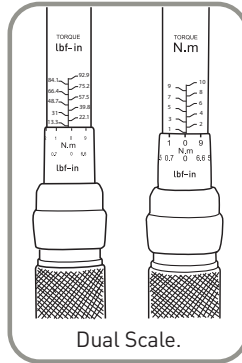

Dual Scale.

CONVERSION TABLE & SPECIFICATIONS

Metric Units

Part No.	Main Torque Range	Secondary Torque Range	Square Drive	Fine Scale	Length (mm)	Width (mm)
K8036	2~10Nm	13.3~92.9 lbf-in	1/4"	0.1 Nm	193	20.2
K8500	10~50Nm	9.2~38.7 lbf-ft	3/8"	0.5 Nm	410	36.4
K8501	40~200Nm	18.4~151.2 lbf-ft	1/2"	1 Nm	520	41
K8502	60~340Nm	36.9~258.1 lbf-ft	1/2"	2 Nm	610	41
K8503	150~750Nm	92.2~571.6 lbf-ft	3/4"	5 Nm	1125	58
K8504	200~1000Nm	92.2~756 lbf-ft	1"	5 Nm	1225	67

FORMULA FOR CALCULATING THE EFFECT OF TORQUE WRENCH EXTENSIONS

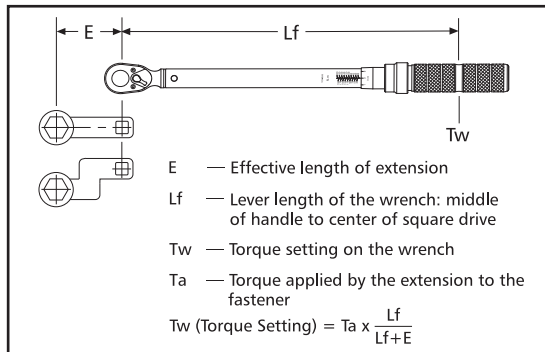

SPARE PARTS

- K8500-1 Repair Kit
- K8500-2 EVA Tray
- K8501-1 Repair Kit
- K8501-2 EVA Tray
- K8502-1 Repair Kit
- K8502-2 EVA Tray
- K8503-1 Repair Kit
- K8504-1 Repair Kit

CARE AND MAINTENANCE

It is normal for torque wrenches to go out of calibration with time and regular use.

Whatever type of torque wrench you are using, regular calibration will ensure that your tools remain as accurate and effective as possible.

Putting in place a regular schedule for verifying and calibrating your torque wrench will mean less room for error.

Kincrome Tools and Equipment recommend you have your torque wrench calibrated by a NATA approved calibration facility, every 12 months or 5,000 cycles.

If your Kincrome Torque Wrench is dropped, knocked, even in the protective blow mould case, or any part replaced, the wrench must be immediately re-calibrated prior to next use.

Your new Kincrome Torque Wrench is calibrated at the factory in Taiwan, prior to shipping and a certificate of that calibration is supplied for your individually serialised torque wrench. It is the sole responsibility of the owner/user of this tool to ensure the calibration is correct as the Torque Wrench may have gone out of calibration during transit to retailers.

For peace of mind, you should get your torque wrench checked prior to first use.

Please note, the Kincrome Limited lifetime warranty does not cover the cost of calibration, or the square drive of the wrench.

Kincrome will not be liable for any damage caused from using an uncalibrated or defective Torque Wrench, due to failing to follow the correct maintenance, calibration and storage instructions within this manual.

WARRANTY

Warranty given by Kincrome Tools & Equipment Pty Ltd of 3 Lakeview Drive, Caribbean Park, Scoresby, Victoria, Australia (Tel +61 3 9730 7100) If this product has materials or workmanship defects (other than defects caused by abnormal or non warranted use) you can, at your cost, send the product to place of purchase, an authorised Kincrome service agent or one of Kincromes addresses for repair or replacement. Your rights under this warranty are in addition to any other rights you have under the Australian, United Kingdom & Ireland Consumer Law or other applicable laws. Our goods come with guarantees that cannot be excluded under the Australian, United Kingdom & Ireland Consumer Law. You are entitled to a replacement or refund for a major failure and compensation for any other reasonably foreseeable loss or damage. You are also entitled to have the goods repaired or replaced if the goods fail to be of acceptable quality and the failure does not amount to a major failure. For further details please visit www.kincrome.com.au or call us. Due to minor changes in design or manufacture, the product you purchase may sometimes differ from the one shown on the packaging.

KINCROME 
PROFESSIONAL QUALITY TOOLS

www.kincrome.com.au